



RÉPUBLIQUE
FRANÇAISE

*Liberté
Égalité
Fraternité*



*maîtriser le risque
pour un développement durable*

1ST INTERNATIONAL WORKSHOP ON REAL-LIFE EMISSIONS

8 – 10 Nov. 2022

University of Eastern Finland, Kuopio campus

**Results from PM sampling methods used during the Ineris measurement campaigns on
the residential wood combustion:**

- Dilution Tunnel, Porous Tube, SPC-IPA method and Dilution Chamber -



Benjamin Cέα: benjamin.cea@ineris.fr



Ineris - [CGR] -

206311

Introduction

Why using dilution methods ? *To include condensables in the measurement, i.e emission factors and inventories*

Why using dilution methods ? To include condensables in the measurement, i.e emission factors and inventories

Why using dilution methods ? To include **condensables** ? in the measurement, i.e emission factors and inventories

- Organic gaseous compounds in stack that **condense** on contact with the atmosphere due to **dilution** and **cooling** of the flue gases
- Represent a large part of air ambient particulates from residential wood combustion (*Nussbaumer et al. 2008*)
- Most emission inventories are based on particle measurements that do not include condensables, leading to an underestimation of European emissions from wood burning by a factor of 2 to 3 (*Danier Van Der Gon et al. 2015*)
- Using EMEP and PMCAMx air quality models, inclusion of condensable emissions from wood burning in the emission inventories could lead to an increase of more than 50% in the in simulated particulate matter concentrations (*Danier Van Der Gon et al. 2015*)

Why using dilution methods ? To include **condensables** ? in the measurement, i.e emission factors and inventories

- Organic gaseous compounds in stack that **condense** on contact with the atmosphere due to **dilution** and **cooling** of the flue gases
- Represent a **large part of air ambient particulates** from residential wood combustion (*Nussbaumer et al. 2008*)
- Most emission inventories are based on particle measurements that do not include condensables, leading to an underestimation of European emissions from wood burning by a factor of 2 to 3 (*Danier Van Der Gon et al. 2015*)
- Using EMEP and PMCAMx air quality models, inclusion of condensable emissions from wood burning in the emission inventories could lead to an increase of more than 50% in the in simulated particulate matter concentrations (*Danier Van Der Gon et al. 2015*)

Why using dilution methods ? To include **condensables** ? in the measurement, i.e emission factors and inventories

- Organic gaseous compounds in stack that **condense** on contact with the atmosphere due to **dilution** and **cooling** of the flue gases
- Represent a **large part of air ambient particulates** from residential wood combustion (*Nussbaumer et al. 2008*)
- Most emission inventories are based on particle measurements that do not include condensables, leading to an **underestimation of European emissions** from wood burning by a **factor of 2 to 3** (*Denier Van Der Gon et al. 2015*)
- Using EMEP and PMCAMx air quality models, inclusion of condensable emissions from wood burning in the emission inventories could lead to an increase of more than 50% in the in simulated particulate matter concentrations (*Danier Van Der Gon et al. 2015*)

Why using dilution methods ? To include **condensables** ? in the measurement, i.e emission factors and inventories

- Organic gaseous compounds in stack that **condense** on contact with the atmosphere due to **dilution** and **cooling** of the flue gases
- Represent a **large part of air ambient particulates** from residential wood combustion (*Nussbaumer et al. 2008*)
- Most emission inventories are based on particle measurements that do not include condensables, leading to an **underestimation of European emissions** from wood burning by a **factor of 2 to 3** (*Denier Van Der Gon et al. 2015*)
- Using EMEP and PMCAMx air quality models, inclusion of condensable emissions from wood burning in the emission inventories could lead to an **increase of more than 50%** in the simulated particulate matter concentrations (*Denier Van Der Gon et al. 2015*)

Why testing appliances using real-life conditions ? To be as representative as possible of the uses domestic combustion appliances.

Why testing appliances using real-life conditions ? **To be as representative as possible of the uses domestic combustion appliances.**

Why testing appliances using real-life conditions ? To be as representative as possible of the uses domestic combustion appliances.

- By incorporating cycles of **nominal** and **low** combustion conditions during the measurements
- The reduced combustion output is a cycle widely used in France (>25% of users) to heat longer by increasing the duration of the fuel (*Ademe report 2018 - Survey on the use of domestic wood-burning equipment - www.ademe.fr/mediatheque*)
- Because the reduced combustion output, produces more condensables (*Nussbaumer et al. 2008*)

Why testing appliances using real-life conditions ? To be as representative as possible of the uses domestic combustion appliances.

- By incorporating cycles of **nominal** and **low** combustion conditions during the measurements
- The **low combustion condition** is widely used condition in France (>25% of users) to heat longer by increasing the duration of the combustion (*Ademe report 2018 - Survey on the use of domestic wood-burning equipment - www.ademe.fr/mediatheque*)
- Because the reduced combustion output, produces more condensables (*Nussbaumer et al. 2008*)

Why testing appliances using real-life conditions ? To be as representative as possible of the uses domestic combustion appliances.

- By incorporating cycles of **nominal** and **low** combustion conditions during the measurements
- The **low combustion condition** is widely used condition in France (>25% of users) to heat longer by increasing the duration of the combustion (*Ademe report 2018 - Survey on the use of domestic wood-burning equipment - www.ademe.fr/mediatheque*)
- Because the **low combustion condition**, produces more **condensables** (*Nussbaumer et al. 2008*)

1. Wood combustion test protocol used on the Ineris experimental platform

1. a. Ineris experimental platform



1. b. Protocol of combustion tests: *from Afac 2015** (Ademe/Ineris project)

« Cold Start » : *Without measurement*



1. Ignition (first Batch)

~1,5kg Wood < 16% humidity + kindling



2. Initial phase (Preheating)

No flame, CO₂ < 4%, Ember bed ~ 3 cm

***Afac 2015, french report:** *Determination of pollutants emission factors of domestic wood stoves.*

1. c. Protocol of combustion tests: *from Afac 2015 (Ademe/Ineris project)*

« Warm Start »: *With measurement*



1. Initial phase
(Preheating)
No flame, $\text{CO}_2 < 4\%$
Ember bed $\sim 3 \text{ cm}$



2. Load
($\sim 1,5 \text{ kg}$ Wood)



3. Combustion tests
Start: straight after wood
load (door closure)
End: No flame, $\text{CO}_2 < 4\%$

1. d. Protocol of combustion tests: *from Afac 2015 (Ademe/Ineris project)*

Combustion Condition:



Nominal and Low Output:

Only changing the air supply with same wood load.

- Nominal condition: draught from **11 to 13 Pa**
- Low condition: draught from **9 to 11 Pa**

Determination of combustion condition (%):

= Power Output / Nominal Power of stove

Power Output (kWh) depends on:

- Input power (kWh);
- Efficiency (%) of stove estimated during the test;
- Characteristics of fuel used (% dry matter of C and H, Lower Calorific Value in kJ/kg of raw fuel)

Combustion mode:
Nominal, Low or
Intermediate conditions

2. Wood combustion tests used for Actions A1 to A2 of Real-Life project

2. a. Set up of the wood combustion tests:

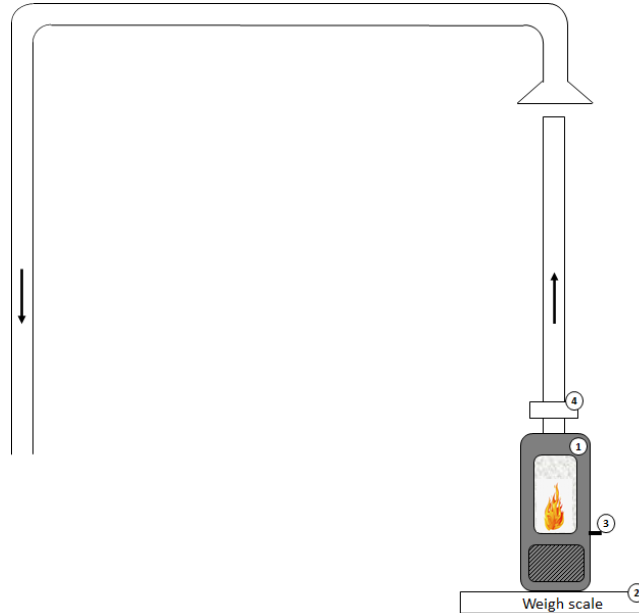

1. Wood log Stove (7 kW). 2. Weighing scale for wood mass consumption. 3. Control of air supply (to change the combustion mode: Nominal, Low, Intermediate conditions). 4. Gasket. 5. Condensator. 6. Heated dilutor. 7. Cold bath (< 4°C). 8. Washing bottles filled with isopropanol (IPA). 9. Filters holders. 10. Silica gel. 11. Pumps. 12. Filter holder for SPE filters. 13. Filter holder for EC/OC filters. 14. AE33 analyser for Black Carbon.

2. a. Set up of the wood combustion tests:

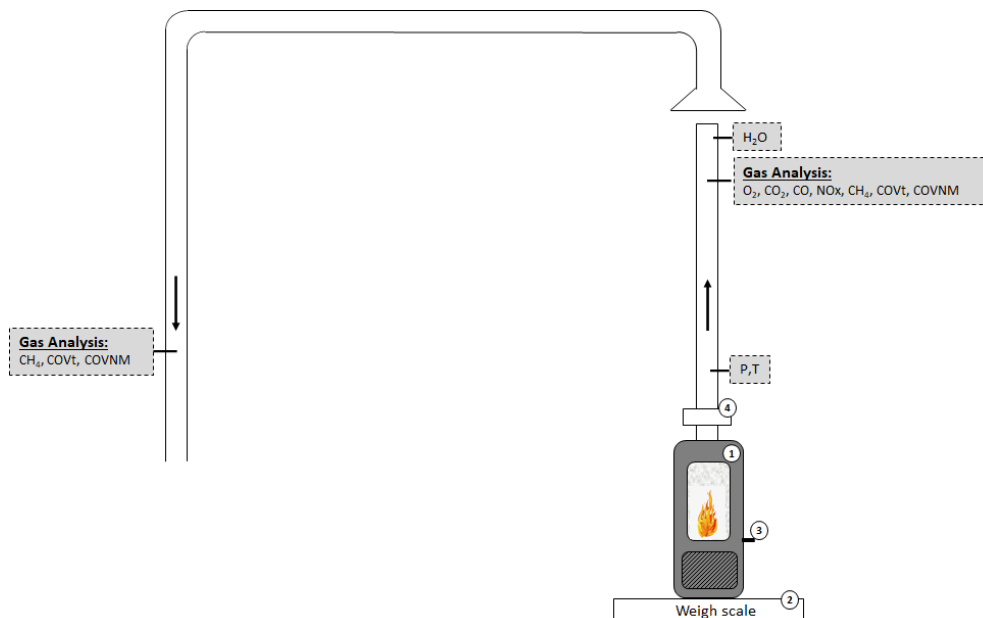

1. Wood log Stove (7 kW). 2. Weighing scale for wood mass consumption. 3. Control of air supply (to change the combustion mode: Nominal, Low, Intermediate conditions). 4. Gasket. 5. Condensator. 6. Heated dilutor. 7. Cold bath (< 4°C). 8. Washing bottles filled with isopropanol (IPA). 9. Filters holders. 10. Silica gel. 11. Pumps. 12. Filter holder for SPE filters. 13. Filter holder for EC/OC filters. 14. AE33 analyser for Black Carbon.

2. a. Set up of the wood combustion tests:

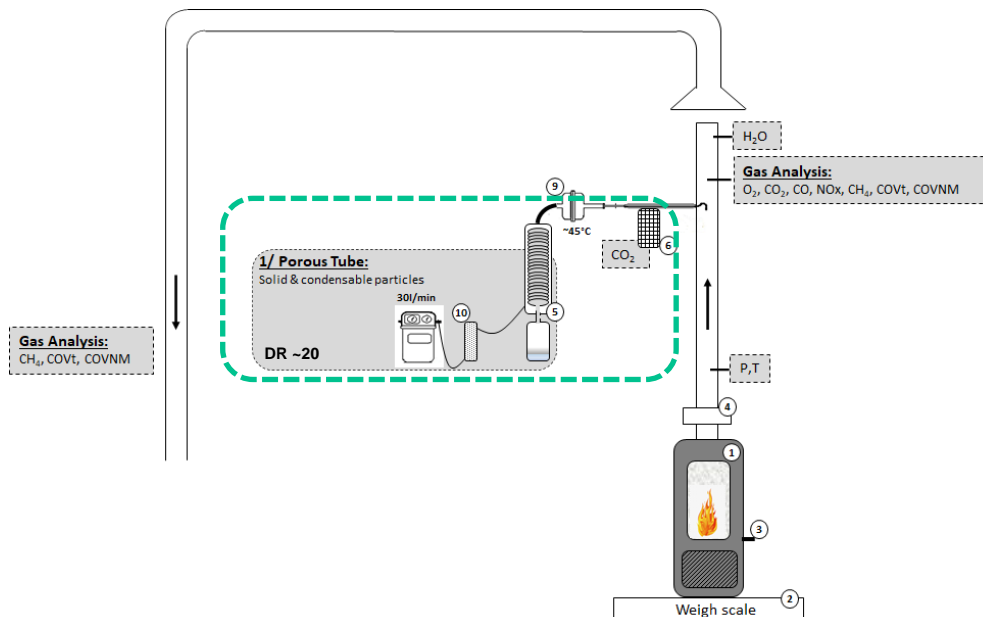

1. Wood log Stove (7 kW).
2. Weighing scale for wood mass consumption.
3. Control of air supply (to change the combustion mode: Nominal, Low, Intermediate conditions).
4. Gasket.
5. Condensator.
6. Heated dilutor.
7. Cold bath ($< 4^{\circ}\text{C}$).
8. Washing bottles filled with isopropanol (IPA).
9. Filters holders.
10. Silica gel.
11. Pumps.
12. Filter holder for SPE filters.
13. Filter holder for EC/OC filters.
14. AE33 analyser for Black Carbon.

2. a. Set up of the wood combustion tests:

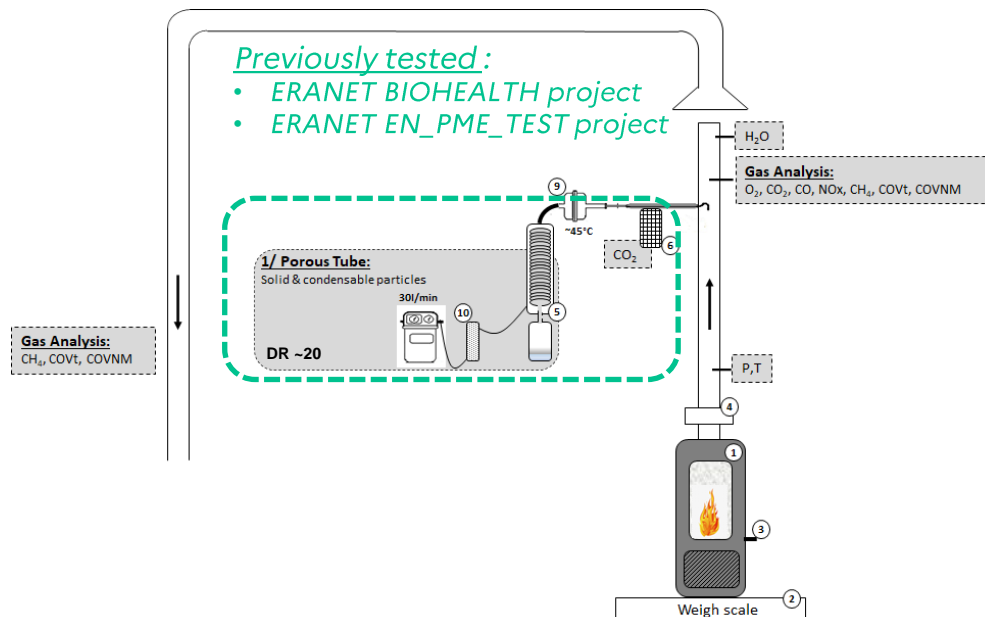

1. Wood log Stove (7 kW). 2. Weighing scale for wood mass consumption. 3. Control of air supply (to change the combustion mode: Nominal, Low, Intermediate conditions). 4. Gasket. 5. Condensator. 6. Heated dilutor. 7. Cold bath (< 4°C). 8. Washing bottles filled with isopropanol (IPA). 9. Filters holders. 10. Silica gel. 11. Pumps. 12. Filter holder for SPE filters. 13. Filter holder for EC/OC filters. 14. AE33 analyser for Black Carbon.

2. a. Set up of the wood combustion tests:

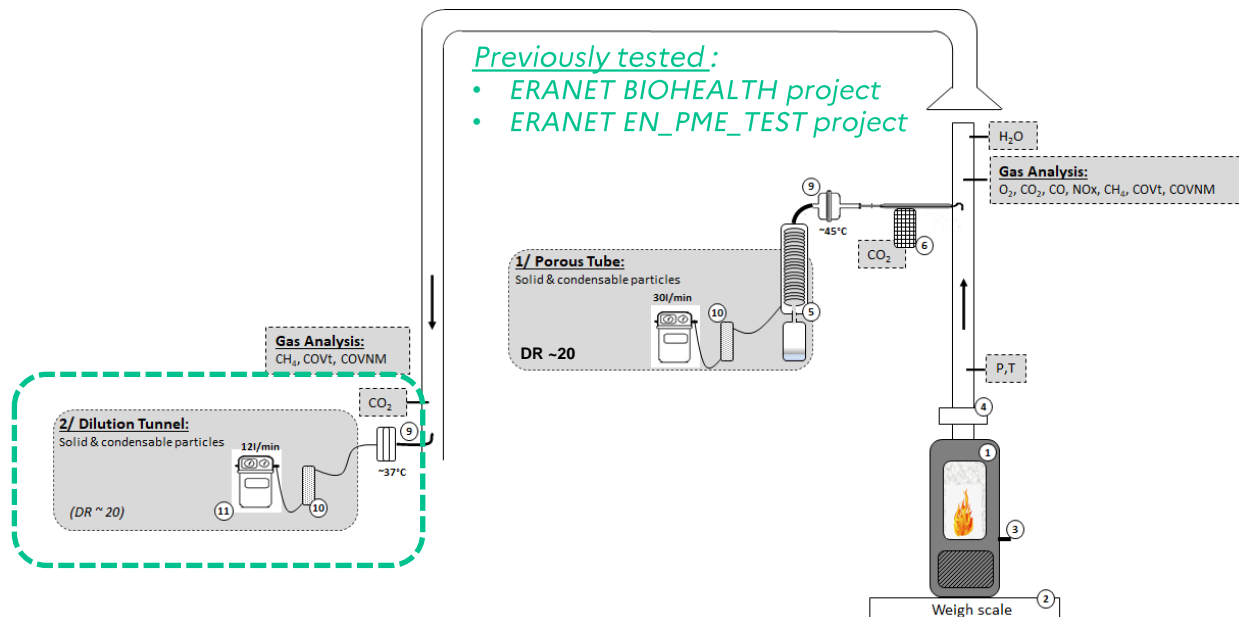

1. Wood log Stove (7 kW).
2. Weighing scale for wood mass consumption.
3. Control of air supply (to change the combustion mode: Nominal, Low, Intermediate conditions).
4. Gasket.
5. Condensator.
6. Heated diluter.
7. Cold bath (< 4°C).
8. Washing bottles filled with isopropanol (IPA).
9. Filters holders.
10. Silica gel.
11. Pumps.
12. Filter holder for SPE filters.
13. Filter holder for EC/OC filters.
14. AE33 analyser for Black Carbon.

2. a. Set up of the wood combustion tests:

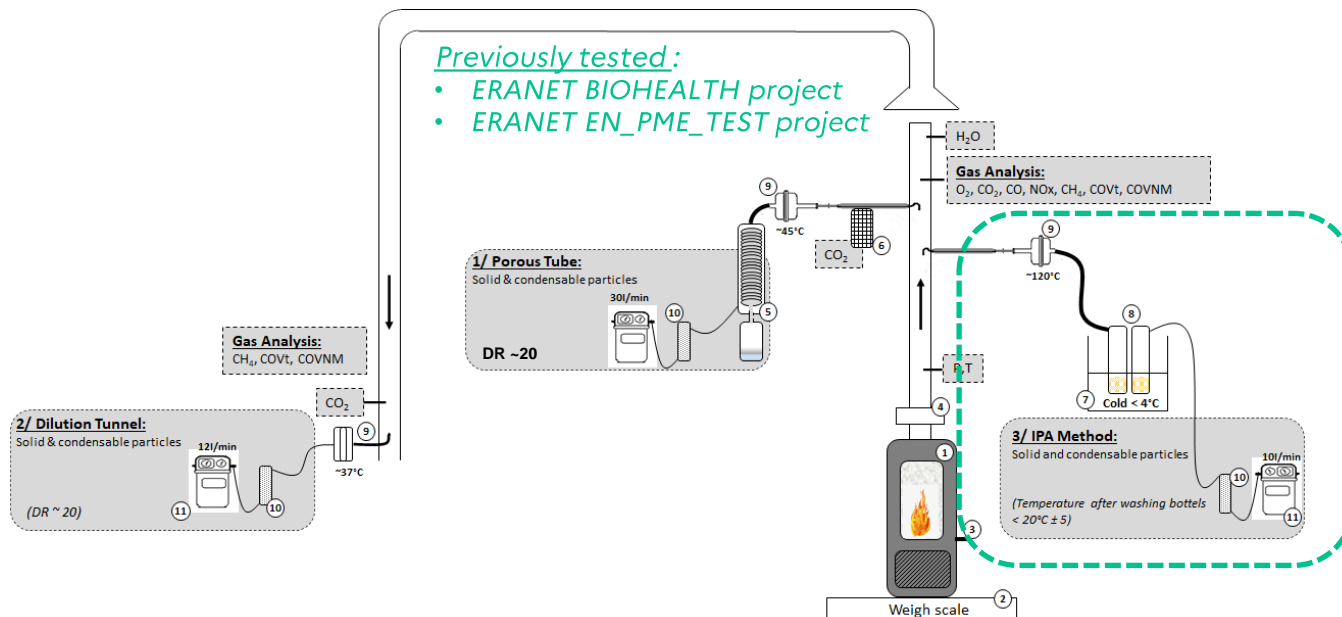

1. Wood log Stove (7 kW). 2. Weighing scale for wood mass consumption. 3. Control of air supply (to change the combustion mode: Nominal, Low, Intermediate conditions). 4. Gasket. 5. Condensator. 6. Heated diluter. 7. Cold bath (<math>< 4^{\circ}\text{C}</math>). 8. Washing bottles filled with isopropanol (IPA). 9. Filters holders. 10. Silica gel. 11. Pumps. 12. Filter holder for SPE filters. 13. Filter holder for EC/OC filters. 14. AE33 analyser for Black Carbon.

2. a. Set up of the wood combustion tests:

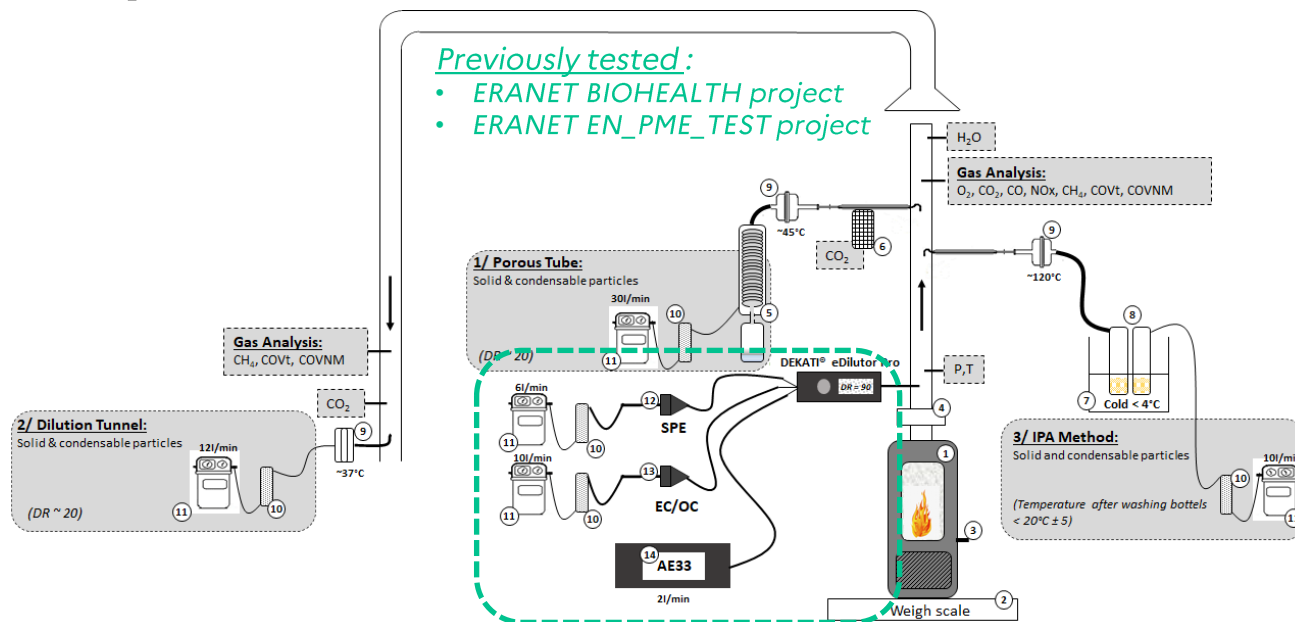

1. Wood log Stove (7 kW).
2. Weighing scale for wood mass consumption.
3. Control of air supply (to change the combustion mode: Nominal, Low, Intermediate conditions).
4. Gasket.
5. Condensator.
6. Heated dilutor.
7. Cold bath ($< 4^{\circ}\text{C}$).
8. Washing bottles filled with isopropanol (IPA).
9. Filters holders.
10. Silica gel.
11. Pumps.
12. Filter holder for SPE filters.
13. Filter holder for EC/OC filters.
14. AE33 analyser for Black Carbon.

2. b. Experimental parameters:

Wood log stove:

FV 7*, 7 kW

Wood type:

Beech and Hornbeam (~1,5 kg)

#combustion tests:

15 combustion tests

Combustion conditions:

From **40 % to 60%** of the nominal power as « **Low** », from **75% to 100%** of the nominal power as « **Nominal** » and between **60% and 75%** of the nominal power as « **Intermediate** »

Time by test:

between 35min. and 1h20

Dilution Ratios (DR): Between **15 and 25** (calculated with CO₂ ratio for the Dilution Tunnel and the Porous Tube methods)

3. Results of Real-Life combustion tests

3. a. PM sampling (solid and condensable): *Dilution Tunnel, Porous Tube and SPC-IPA methods*

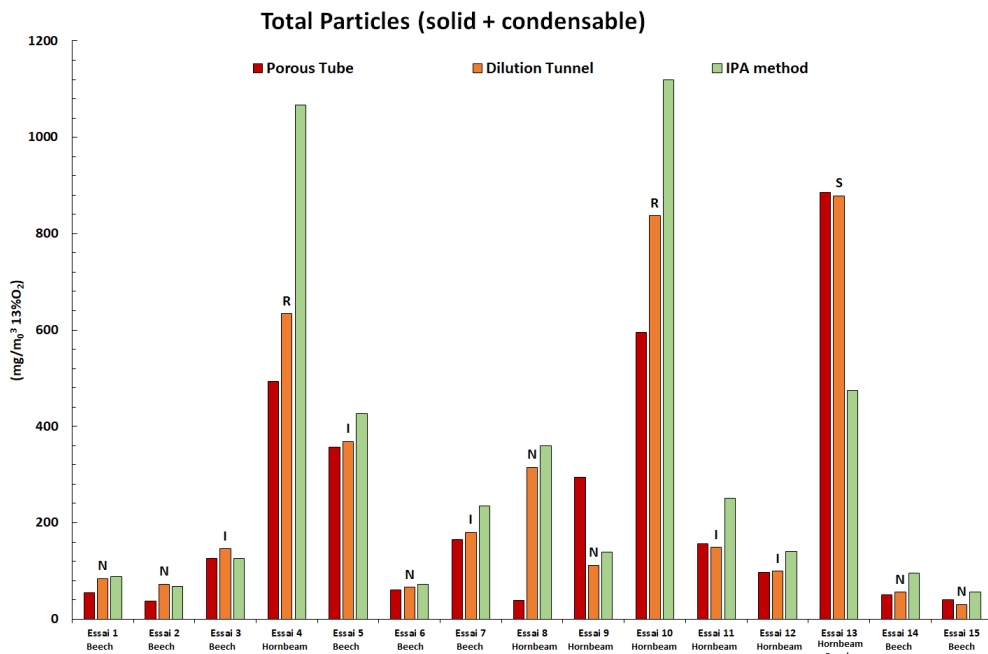

Combustion Conditions:

- N: Nominal (75 – 100%)
- I: Intermediate (60 – 75%)
- R: for Low (40 – 60%)
- S: « Cold Start »

3. b. PM sampling (solid and condensable): Comparison between *Porous Tube* and *Dilution Tunnel* methods

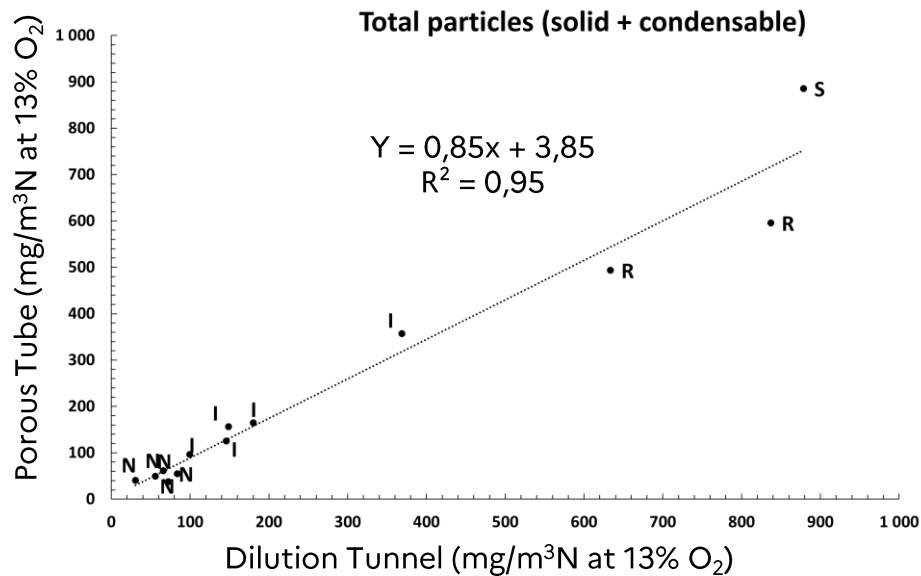

3. b. PM sampling (solid and condensable): Comparison between *Porous Tube and Dilution Tunnel methods*

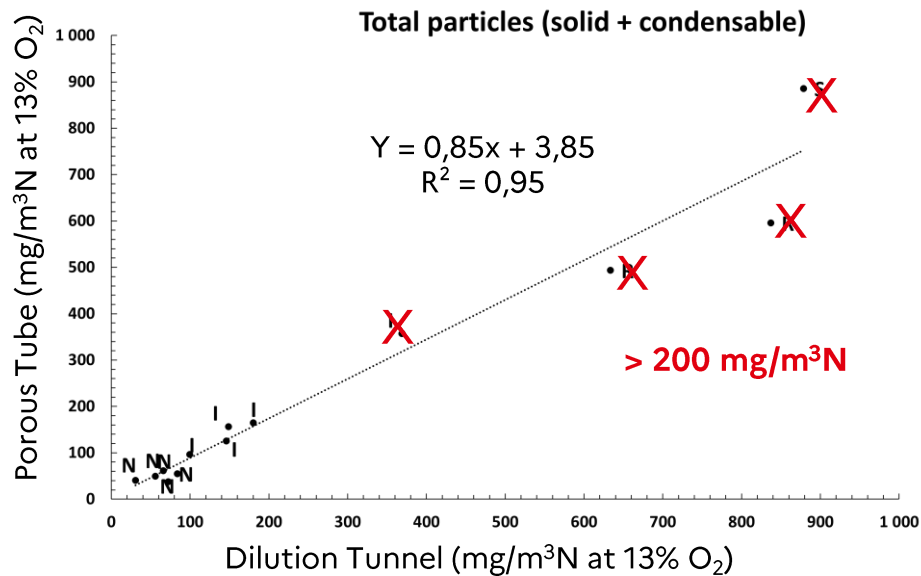

3. b. PM sampling (solid and condensable): Comparison between *Porous Tube* and *Dilution Tunnel* methods

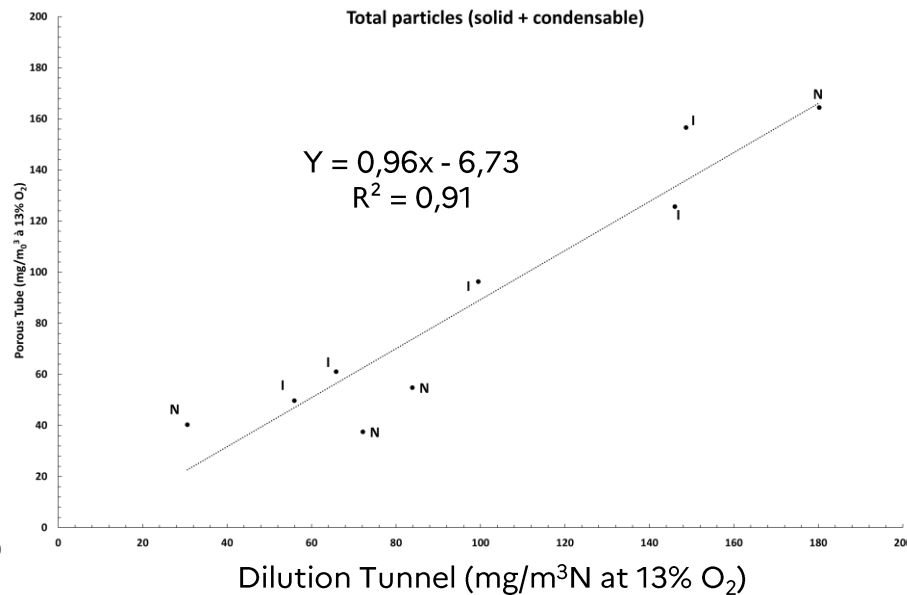
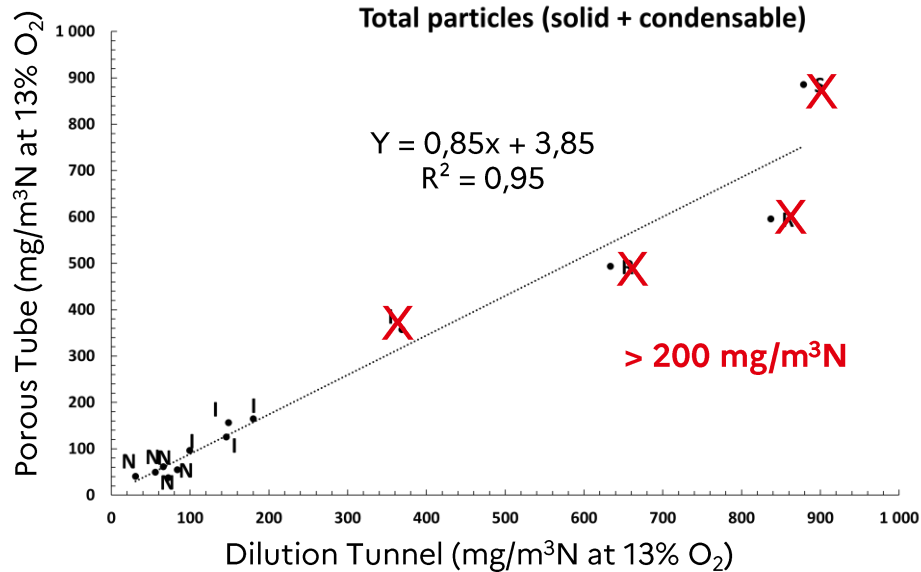

3. c. PM sampling (solid and condensable): Comparison between *SPC-IPA* and *Porous Tube* methods

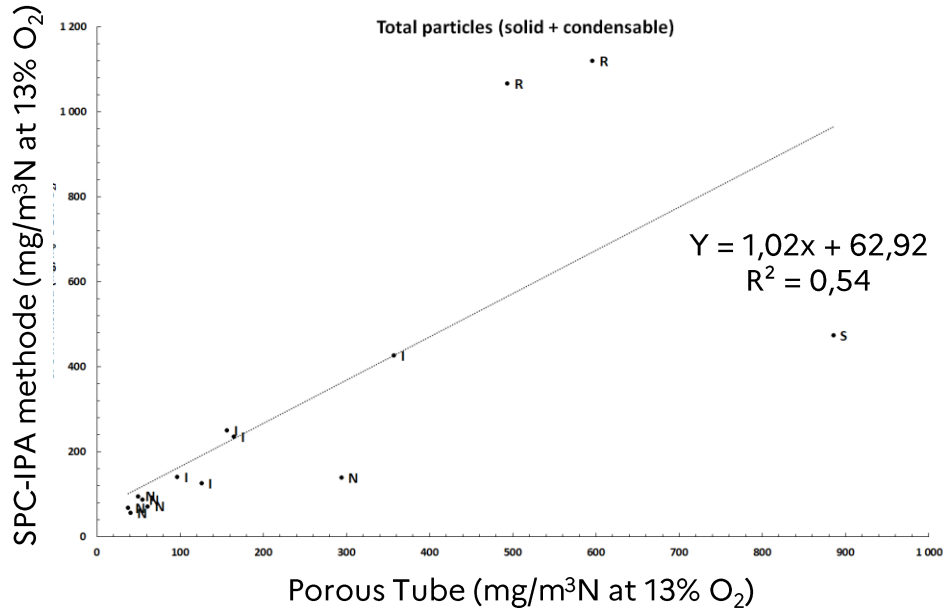

3. c. PM sampling (solid and condensable): Comparison between *SPC-IPA* and *Porous Tube* methods

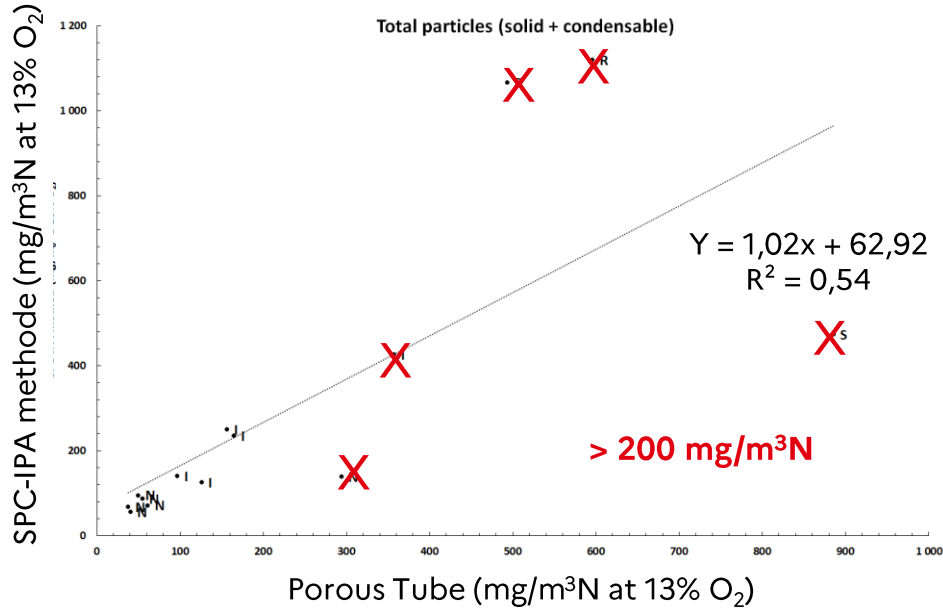

3. c. PM sampling (solid and condensable): Comparison between SPC-IPA and Porous Tube methods

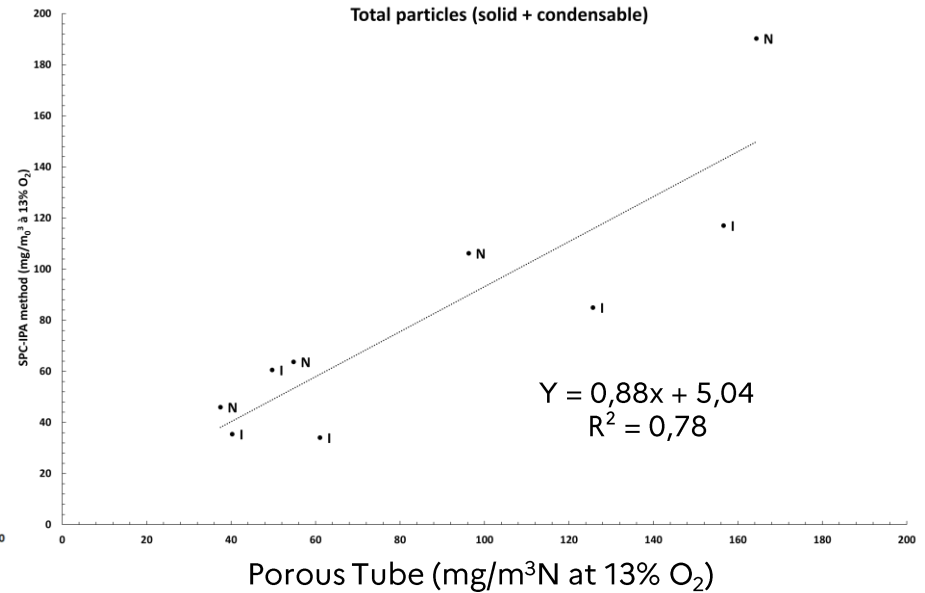
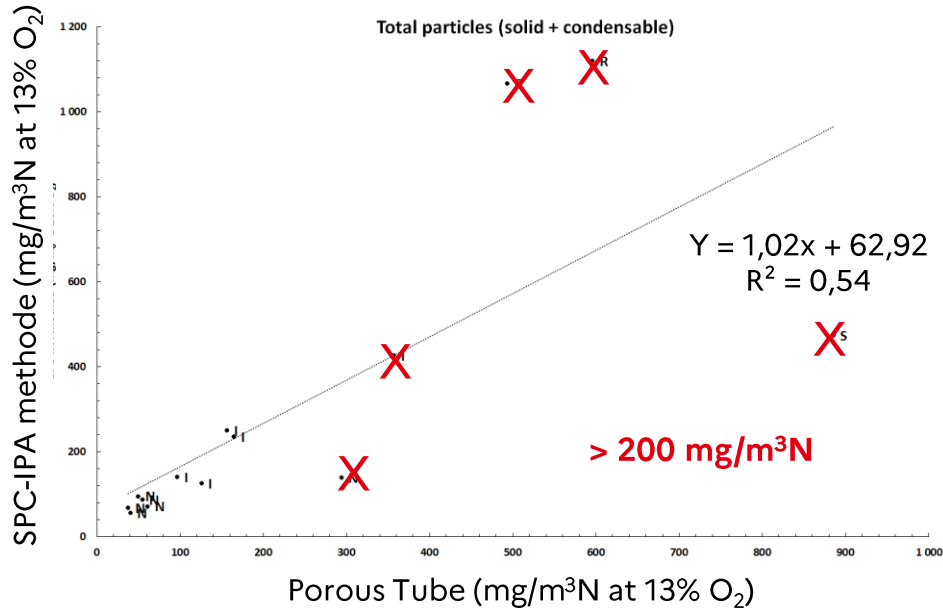

3. d. PM sampling (solid and condensable):

Wood log stove: Comparison between Dilution Tunnel, Porous Tube and SPC-IPA methods

Combustion conditions	n	DT method	PT method	SPC-IPA method
		Mean PM (mg/m ³ N)		
Nominal	7	104	87	126
Intermediate	5	189	180	236
Low	2	735	545	1093
<i>Limit of quantification*</i>	<i>LOQ</i>	<i>36,7</i>	<i>15,4</i>	<i>7,1</i>

**Limit of quantification = LOQ = Analytical limit / sampled volume*

4. Wood combustion tests performed within the Impress 2 project

EMPIR Grant Agreement 16ENV08 IMPRESS 2 v1.0

EMPIR



EURAMET



**Horizon 2020
European Union Funding
for Research & Innovation**

The EMPIR initiative is co-funded by the European Union's Horizon 2020 research and innovation programme and the EMPIR Participating States

4. b. PM sampling (solid and condensable):

Dilution Chamber method:

- The dilution system has been designed to operate with small biomass appliances, like stoves, fireplaces and domestic boilers, fed with wood fuel (wood logs, pellets, briquettes and wood chips) and tested to sample both the solid and condensable fractions of PM.
- Technology developed by Innovhub, ENEA and Dado Lab
- Complete design features are described in the study of *Hugony et al. 2019*.

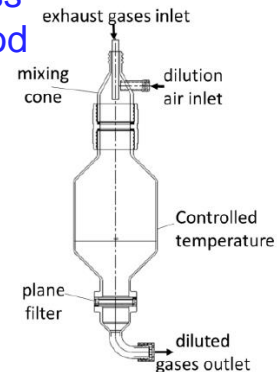

4. c. Set up of the wood combustion tests: **Impress 2**

80 combustions tests carried out by 5 european institutes: ENEA, ISSI (Italy), Ineris (France), DTI (Denmark) and RISE (Sweden) – With wood log and pellet stoves

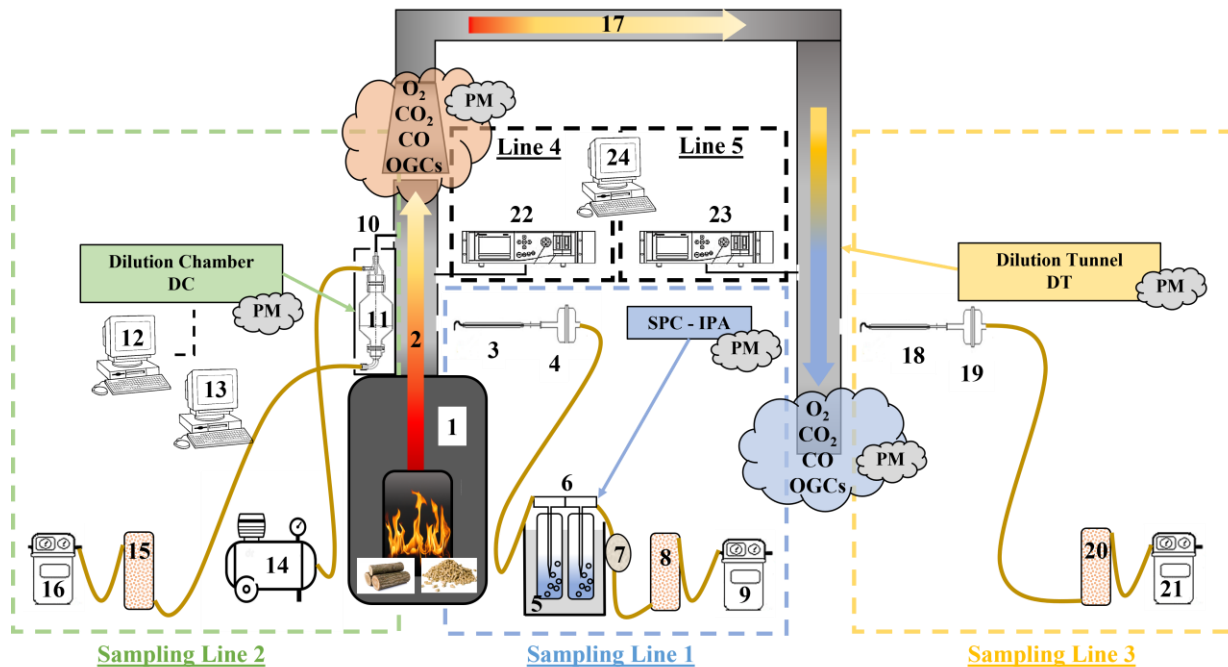

5. Results of Impress 2 combustion tests

5. a. PM sampling (solid and condensable): Comparison between *Dilution Chamber* and *Dilution Tunnel* methods

All combustion tests
(Residential pellet and wood stoves)

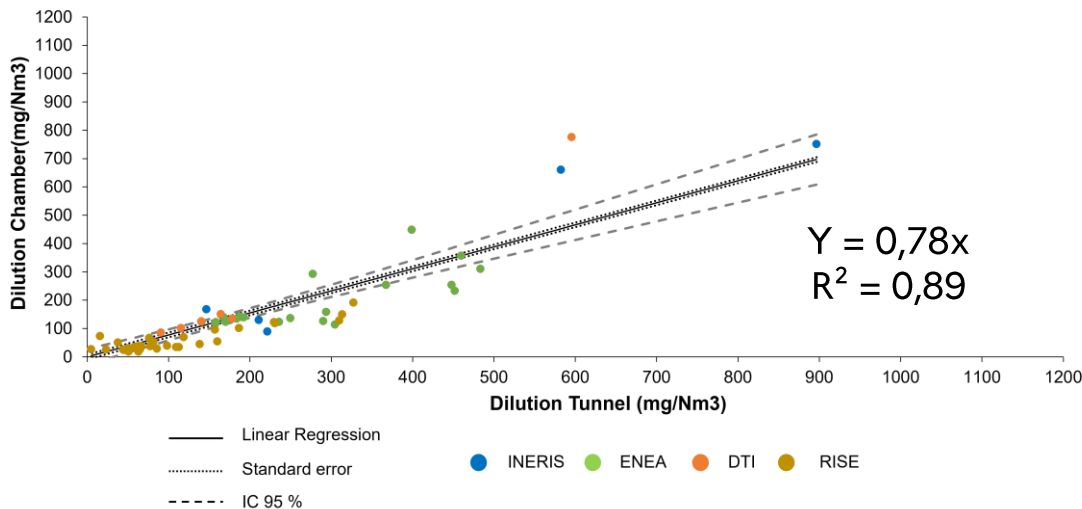

5. b. PM sampling (solid and condensable):

Pellet stove: Comparison between Dilution Chamber and Dilution Tunnel

Institutes	n	DC method	DT method	R ²
		Mean PM (mg/m ³ N)		
Ineris	-	-	-	-
ENEA, ISSI	10	129	167	0,99
DTI	-	-	-	-
RISE	6 (nominal)	33	38	0,93
	7 (low)	118	220	0,93
<i>LOQ</i>		<i>18,3</i>	<i>58,9</i>	

Data from the study of C ea et al. 2021

5. c. PM sampling (solid and condensable):

Wood log stove: Comparison between Dilution Chamber and Dilution Tunnel

Institutes	n	DC method	DT method	R ²
		Mean PM (mg/m ³ N)		
Ineris	3 (<i>nominal</i>)	121	145	0,96
	3 (<i>low</i>)	501	567	
ENEA, ISSI	12	235	355	0,91
DTI	6	230	214	0,98
RISE	18	44	91	0,93
<i>LOQ</i>		<i>16,3</i>	<i>53,3</i>	

Data from the study of C ea et al. 2021

5. a. PM sampling (solid and condensable):

Dilution Tunnel, SPC-IPA methods and Dilution Chamber

energy&fuels

pubs.acs.org/EF

Article

1 Development and Evaluation of an Innovative Method Based on 2 Dilution to Sample Solid and Condensable Fractions of Particles 3 Emitted by Residential Wood Combustion

4 Benjamin Cea,* Isaline Fraboulet, Océane Feuger, Francesca Hugony, Carmen Morreale,
5 Gabriele Migliavacca, Jes Sig Andersen, Morten Gottlieb Warming-Jespersen, Daniel Bäckström,
6 and Sara Janhäll



Cite This: <https://doi.org/10.1021/acs.energyfuels.1c02595>



Read Online

5. a. PM sampling (solid and condensable): Dilution Tunnel, SPC-IPA methods and Dilution Chamber

energy&fuels

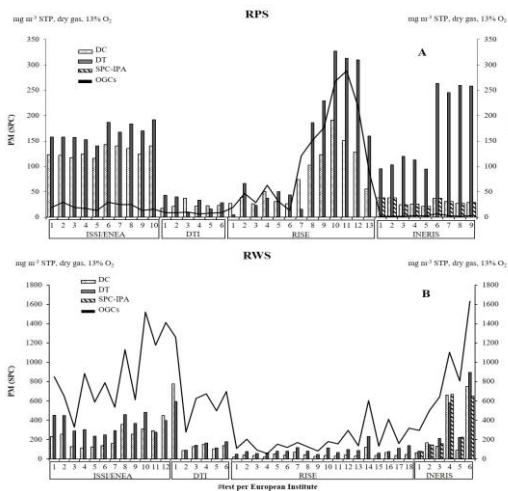

Comparison and Evaluation of an Innovative Method to Sample Solid and Condensable Fractions of Residential Wood Combustion

Christine Fraboulet, Océane Feuger, Francesca Hugony, Carmen Moller, Jes Sig Andersen, Morten Gottlieb Warming-Jespersen, Danie

<https://doi.org/10.1021/acs.energyfuels.1c02595>

Read Online

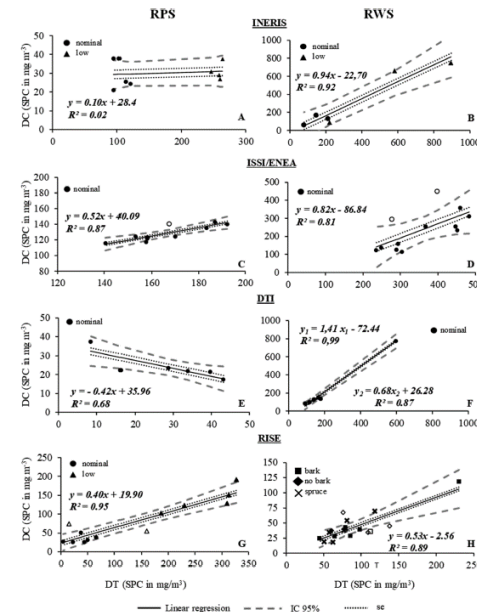

5. d. PM sampling (solid and condensable): Other projects with the Dilution Chamber method:

- Profile Pizza an Italian project on emission from wood pizza ovens
- REMY LIFE project that investigates the impact of uncertainty in pollutants emission and air dispersion models that could negatively affect air quality plan

For these projects, the dilution system layout has been implemented with a refrigerating unit which allows to work with low temperature dilution air (0°C) in order to simulate winter conditions of dilution.

This new version of the system can cover a large range of dilution ratio and temperature.

Conclusions

Real-Life project: Porous Tube methode (PT)

- Good correlations between the Porous Tube and the Dilution Tunnel ($R^2 > 0,9$) or SPC-IPA methode ($R^2 = 0,78$) at concentrations below 200 mg/m³N
 - ✓ Porous Tube advantages:
 - Sampling solid and condensable fractions of PM
 - Dilution method all terrain compared to the Dilution Tunnel = can be moved
 - Low investment required = low-cost method
 - LQ of Porous tube < LQ of Dilution Tunnel
 - ✓ Porous Tube disadvantage:
 - Need to control the dilution rate with a tracer gas (CO₂)

Perspectives:

- Replace the tracer gas method with a dilution rate control based on dilution air supply depending on the evolution of the flue gas temperature = same system as Dilution Chamber.
- PT need to be used with low PM concentrations (< 50 mg/Nm³)
- Decreased the LQ of PT (increase the sampling flow rate or increase the time sampling)
- PT to be used in the intercomparison of methods (Action A4 for Real Life project)

Real-Life project: Porous Tube methode (PT)

- Good correlations between the Porous Tube and the Dilution Tunnel ($R^2 > 0,9$) or SPC-IPA methode ($R^2 = 0,78$) at concentrations below $200 \text{ mg/m}^3\text{N}$
 - ✓ Porous Tube advantages:
 - Sampling solid and condensable fractions of PM
 - Dilution method all terrain compared to the Dilution Tunnel = can be moved
 - Low investment required = low-cost method
 - LOQ of Porous tube < LOQ of Dilution Tunnel
 - ✓ Porous Tube disadvantage:
 - Need to control the dilution rate with a tracer gas (CO_2)

Perspectives:

- Replace the tracer gas method with a dilution rate control based on dilution air supply depending on the evolution of the flue gas temperature = same system as Dilution Chamber.
- PT need to be used with low PM concentrations ($< 50 \text{ mg/Nm}^3$)
- Decreased the LQ of PT (increase the sampling flow rate or increase the time sampling)
- PT to be used in the intercomparison of methods (Action A4 for Real Life project)

Real-Life project: Porous Tube methode (PT)

- Good correlations between the Porous Tube and the Dilution Tunnel ($R^2 > 0,9$) or SPC-IPA methode ($R^2 = 0,78$) at concentrations below $200 \text{ mg/m}^3\text{N}$
 - ✓ Porous Tube advantages:
 - Sampling solid and condensable fractions of PM
 - Dilution method all terrain compared to the Dilution Tunnel = can be moved
 - Low investment required = low-cost method
 - LOQ of Porous tube < LOQ of Dilution Tunnel
 - ✓ Porous Tube disadvantage:
 - Need to control the dilution rate with a tracer gas (CO_2)

Perspectives:

- Replace the tracer gas method by a dilution rate control based on dilution air supply depending on the evolution of the flue gas temperature = same system as Dilution Chamber.
- Decrease the LOQ of PT (increase the sampling flow rate or increase the time sampling) to be able to use it at low PM concentrations ($< 50 \text{ mg/Nm}^3$)
- PT to be used in the intercomparison of methods (Action A4 for Real Life project)

Impress 2 project:

- Good correlations between the Dilution Chamber and the Dilution Tunnel ($R^2 > 0,9$)
 - ✓ Dilution Chamber advantages:
 - Sampling solid and condensable fractions of PM
 - Dilution method all terrain and more compact compared to the Dilution Tunnel
 - Automated adjustment of sampling temperature and DR in the chamber
 - LQ of Dilution Chamber < LQ Dilution Tunnel
 - ✓ Dilution Chamber method disadvantages:
 - Investment cost = between 20 and 30 k€
 - Not easy to implementation = required qualified personnel
 - There is only one prototype developed by Innovhub and Dado Lab (Italy)

Perspectives:

- Continue to make further measurements with this device during combustion tests.
- Improve the dilution chamber system (decrease the LQ) – *projets des italiens ???*

Impress 2 project:

- Good correlations between the Dilution Chamber and the Dilution Tunnel ($R^2 > 0,9$)
 - ✓ Dilution Chamber advantages:
 - Sampling solid and condensable fractions of PM
 - Dilution method all terrain and more compact compared to the Dilution Tunnel
 - Automated adjustment of sampling temperature and DR in the chamber
 - LOQ Dilution Chamber < LOQ Dilution Tunnel
 - ✓ Dilution Chamber method disadvantages:
 - Investment cost = between 20 and 30 k€
 - Not easy to implement = requires qualified personnel
 - Only one prototype developed by Innovhub and Dado Lab (Italy)

Perspectives:

- Continue to make further measurements with this device during combustion tests.
- Improve the dilution chamber system (decrease the LQ) – *projets des italiens ???*

Impress 2 project:

- Good correlations between the Dilution Chamber and the Dilution Tunnel ($R^2 > 0,9$)
 - ✓ Dilution Chamber advantages:
 - Sampling solid and condensable fractions of PM
 - Dilution method all terrain and more compact compared to the Dilution Tunnel
 - Automated adjustment of sampling temperature and DR in the chamber
 - LOQ Dilution Chamber < LOQ Dilution Tunnel
 - ✓ Dilution Chamber method disadvantages:
 - Investment cost = between 20 and 30 k€
 - Not easy to implement = requires qualified personnel
 - Only one prototype developed by Innovhub and Dado Lab (Italy)

Perspectives:

Not tested in Real-Life project

- Continue to make further measurements with this device during combustion tests.
- Improve the dilution chamber system (decrease the LOQ)

Thank you for your attention